



Power Bridge Rectifiers

SKB 15

Features

- Square plastic case with screw terminals
- Blocking voltage up to 1600 V
- Metal baseplate for improved heat transfer

Typical Applications

- Internal power supplies for electronic equipment
- Electronic control equipment
- DC motors
- Field rectifiers for DC motors
- Battery charger rectifiers
- Recommended snubber network:
RC: 100 nF, 20...50 Ω ($P_R = 1 \text{ W}$)

1) Freely suspended or mounted on an insulator

2) Mounted on apainted metal sheet of min. 250 x 250 x 1 mm

V_{RSM}, V_{RRM} V	V_{VRMS} V	$I_D = 15 \text{ A} (T_c = 117^\circ\text{C})$ Types	C_{max} μF	R_{min} Ω
200	60	SKB 15/02 A2		0,15
400	125	SKB 15/04 A2		0,3
800	250	SKB 15/08 A2		0,5
1200	380	SKB 15/12 A2		0,75
1400	440	SKB 15/14 A2		0,9
1600	500	SKB 15/16 A2		1

Symbol	Conditions	Values	Units
I_D	$T_a = 45^\circ\text{C}$, isolated ¹⁾ $T_a = 45^\circ\text{C}$, chassis ²⁾	5 11	A A
I_{DCL}	$T_a = 45^\circ\text{C}$, isolated ¹⁾ $T_a = 45^\circ\text{C}$, chassis ²⁾ $T_a = 45^\circ\text{C}$, P5A/100	4 9 14	A A A
I_{FSM}	$T_{vj} = 25^\circ\text{C}$, 10 ms $T_{vj} = 150^\circ\text{C}$, 10 ms	370 320	A A
i^2t	$T_{vj} = 25^\circ\text{C}$, 8,3 ... 10 ms $T_{vj} = 150^\circ\text{C}$, 8,3 ... 10 ms	680 500	A ² s A ² s
V_F	$T_{vj} = 25^\circ\text{C}$, $I_F = 150 \text{ A}$	max. 2,2	V
$V_{(T0)}$	$T_{vj} = 150^\circ\text{C}$	max. 0,85	V
r_T	$T_{vj} = 150^\circ\text{C}$	max. 12	mΩ
I_{RD}	$T_{vj} = 25^\circ\text{C}$, $V_{RD} = V_{RRM}$ $T_{vj} = ^\circ\text{C}$, $V_{RD} = V_{RRM} \geq V$	300	μA μA
I_{RD}	$T_{vj} = 150^\circ\text{C}$, $V_{RD} = V_{RRM}$ $T_{vj} = ^\circ\text{C}$, $V_{RD} = V_{RRM} \geq V$	5	mA mA
t_{tr}	$T_{vj} = 25^\circ\text{C}$	10	μs
f_G		2000	Hz
$R_{th(j-a)}$	isolated ¹⁾ chassis ²⁾	12 4,3	K/W K/W
$R_{th(j-c)}$	total	1	K/W
$R_{th(c-s)}$	total	0,3	K/W
T_{vj}		- 40 + 150	°C
T_{stg}		- 55 ... + 150	°C
V_{isol}	a.c. 50 ... 60 Hz; r.m.s.; 1 s / 1 min.	3000/2500	V~
M_s	to heatsink	1,5 ± 15 %	Nm
M_t	to terminals	1 ± 15 %	Nm
a			m/s ²
w		65	g
F_u		20	A
Case		G 9	

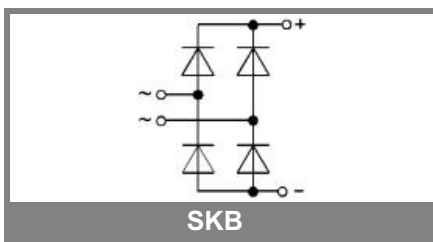

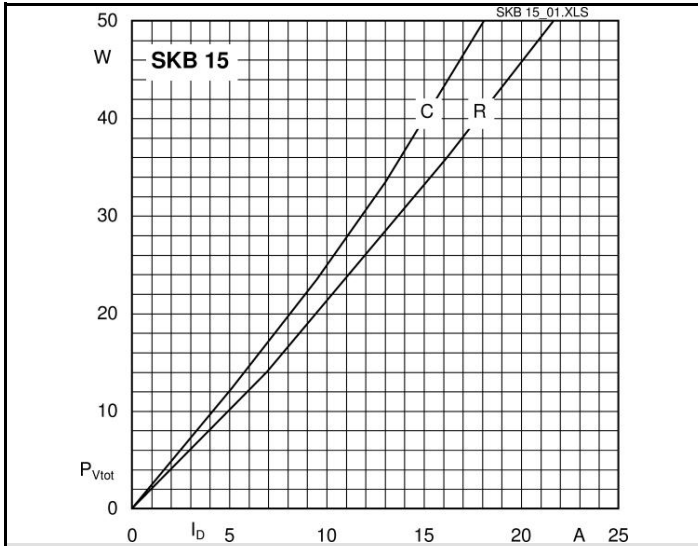

Fig. 1 Power dissipation vs. output current

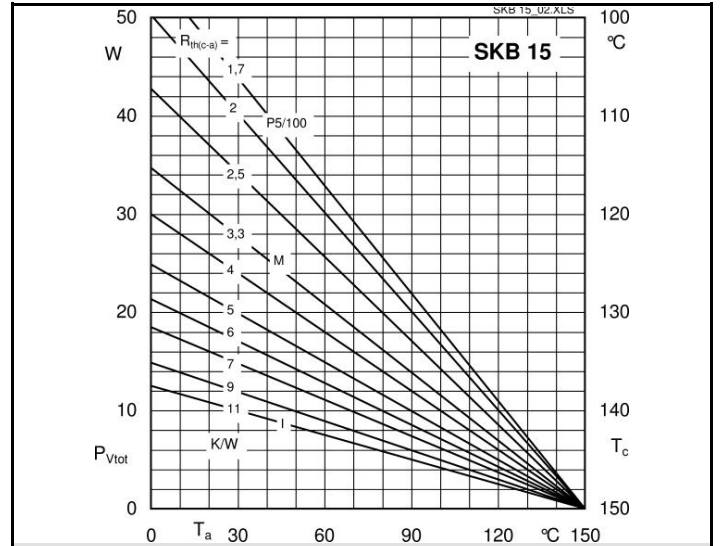

Fig. 2 Power dissipation vs. case temperature

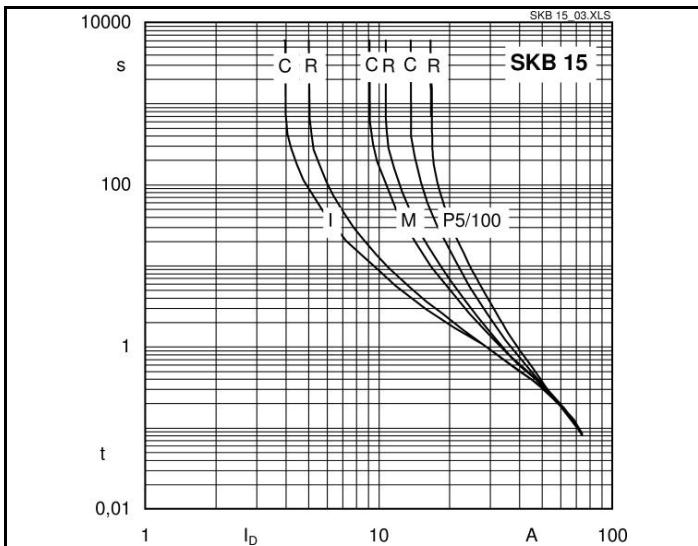

Fig. 6 Rated overload characteristics vs. time

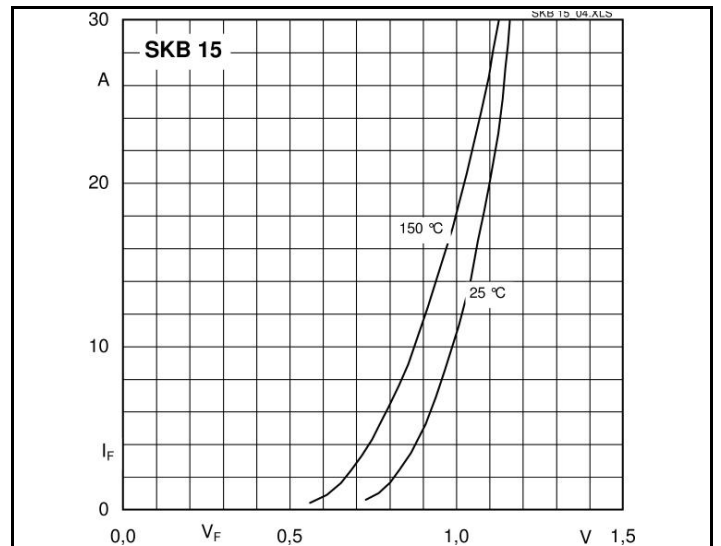
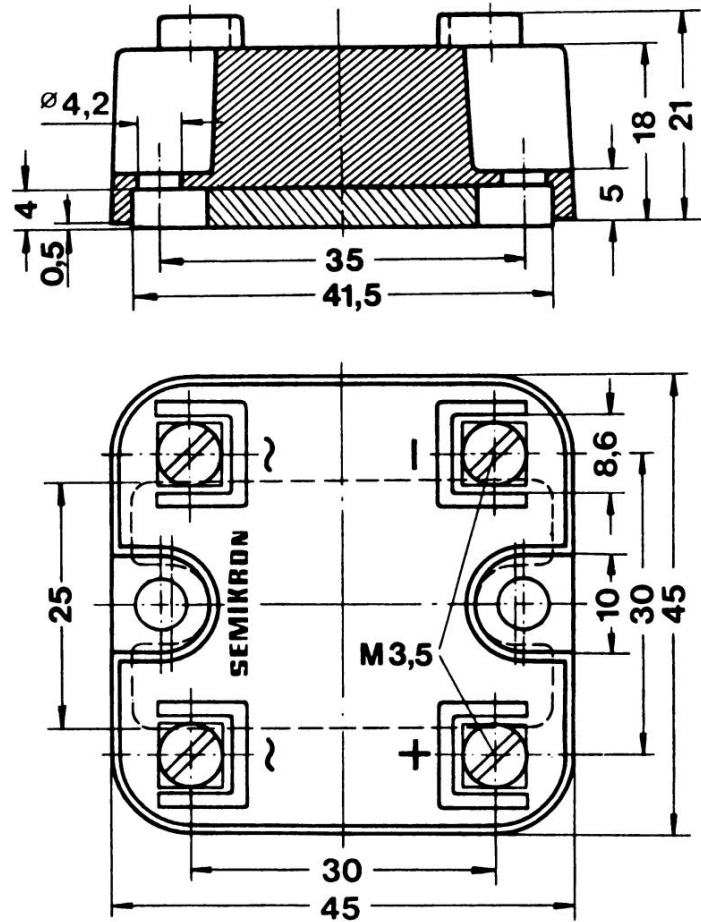

Fig. 9 Forward characteristics of a diode arm



Case G 9

This technical information specifies semiconductor devices but promises no characteristics. No warranty or guarantee expressed or implied is made regarding delivery, performance or suitability.